



# TIGER

## CRANES

### Model 5031E Specifications

#### Model 5031E Specifications

##### Dimensional Specifications:

- 21' Reach
- 12-21' Hydraulic Boom Extension
- 18.5' Lifting Height
- 36" Storage Height
- 159" Overall Storage Length
- Ø18" Mounting Space Required
- 6 Bolt Mounting Pattern
- 5/16" X 120' Winch Cable
- 1395 lbs. Operating Weight
- Ø38.25" Rotation Clearance Required

##### Performance Specifications:

- 30,000 ft-lb Crane Rating
- 36,100 ft-lb Maximum Crane Lifting Moment
- 5,000 lb Double Line Lift Capacity
- 400 Degrees of Rotation
- -8 Degrees to +81 Degrees Boom Angle
- Winch Performance:

LOAD	PART LINE	LIFTING SPEED
0 lbs	1	40 FPM
3250 lbs	2	16 FPM

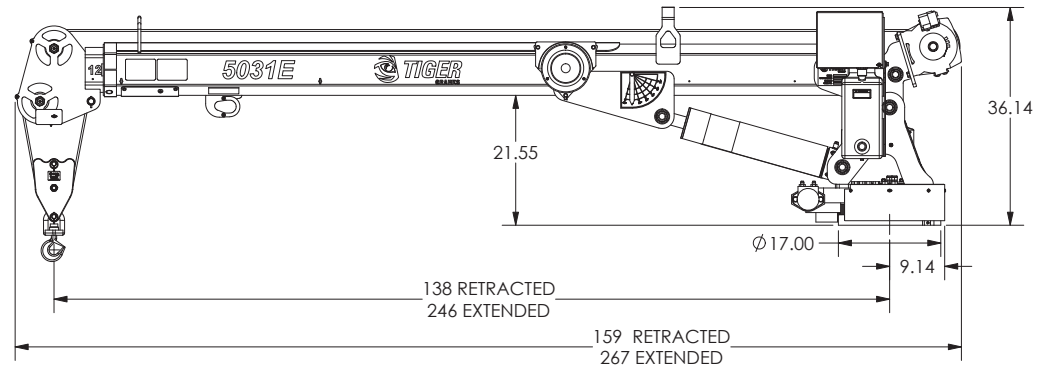

##### Standard Features:

- 25' tethered control included for operation
- Anti two block & overload protection with lighted indication
- 10 VDC Cartridge Valves with manual overrides
- Electric planetary winch. Boom mounted for easier stowing.
- Sealed turret
- Crane lift and extension cylinders are equipped with counterbalance safety valves.
- Powder coated base, turret shield and inner boom, with PPG Delfleet polyurethane paint on other components.
- This crane is designed to meet the requirements of ANSI/ASME B30.5 (2011) and OSHA 1910.180.

##### Optional Features:

###### Available on model 5031EP

- Proportional Wireless Control with 2 way remote to receiver communication, including 3 hydraulic functions with proportional trigger, 1 on/off winch function with trigger interlock, horn button, engine start/stop switch and engine speed control and accessory switch. Requires 4 AA batteries.
- Load percentage indication with 4 character display on remote.
- 33' tether cable included for operation without batteries or in areas where radio transmission is not allowed.

##### Minimum Chassis/Power Requirements:

- 14,500 lbs. GVW Rating
- 60" Cab to Axle
- 300,000 in-lb frame RBM
- 30,000 ft-lb Rated Outtrigger
- 90 Amp Alternator
- 700 Cold Cranking Amp Battery



# TIGER

## CRANES

### Model 5031E Specifications

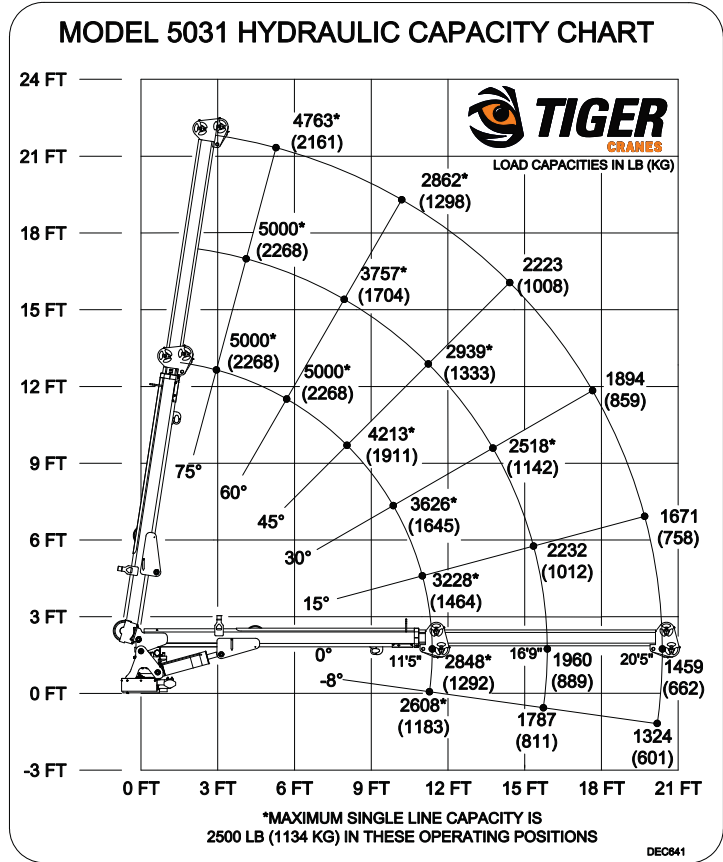

#### Bolt Hole Pattern

