



TIGER

CRANES

Model 5031 Specifications

Model 5031 Specifications

Dimensional Specifications:

- 21' Reach
- 12-21' Hydraulic Boom Extension
- 18.5' Lifting Height
- 36" Storage Height
- 159" Overall Storage Length
- Ø18" Mounting Space Required
- 6 Bolt Mounting Pattern
- 5/16" X 120' Winch Cable
- 1380 lbs. Operating Weight
- Ø38.25" Rotation Clearance Required

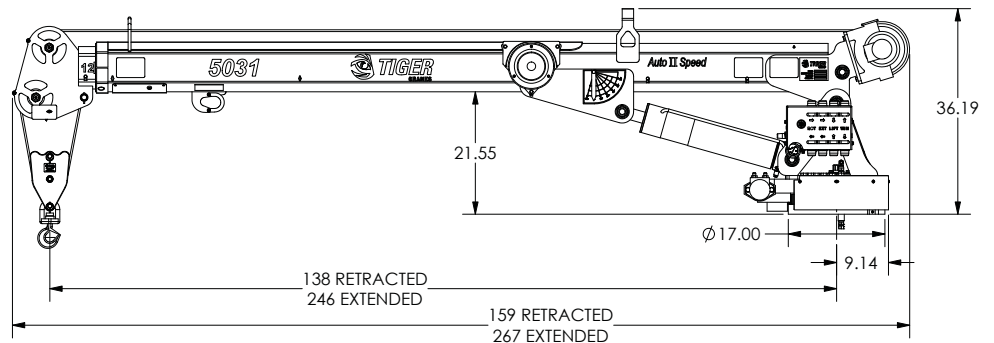

Performance Specifications:

- 30,000 ft-lb Crane Rating
- 36,100 ft-lb Maximum Crane Lifting Moment
- 5,000 lb Double Line Lift Capacity
- 11 second Boom Elevation Time
- 19 second Boom Extension Time
- 1.1 RPM Rotation Speed
- 70 FPM No Load Single Line Speed
- 400 Degrees of Rotation
- -8 Degrees to +81 Degrees Boom Angle

Standard Features:

- Wireless Control with 2 way remote to receiver communication, including 4 hydraulic functions with proportional trigger, horn button, engine start/stop switch and engine speed control and accessory switch. Requires 4 AA batteries.
- Load percentage indication with 4 character display on remote.
- 33' tether cable included for operation without batteries or in areas where radio transmission is not allowed.
- Anti two block & overload protection with condition indicators on remote.
- Sealed turret
- Integrated filtration with bypass condition indicator.
- 12 VDC DO3 10 GPM solenoids with manual overrides & LED On/Off indicator DIN connectors
- Hydraulic planetary winch. Boom mounted for easier stowing.
- Crane lift and extension cylinders are equipped with counterbalance safety valves.
- Powder coated base, turret shield and inner boom, with PPG Delfleet polyurethane paint on other components.
- This crane is designed to meet the requirements of ANSI/ASME B30.5 (2011) and OSHA 1910.180.

Minimum Requirements:

- 14,500 lbs. GVW Rating
- 60" Cab to Axle
- 300,000 in-lb frame RBM
- 8 GPM @ 2750 PSI – open center hydraulics
- 30,000 ft-lb rated crane tower reinforcement and outrigger



TIGER

CRANES

Model 5031 Specifications

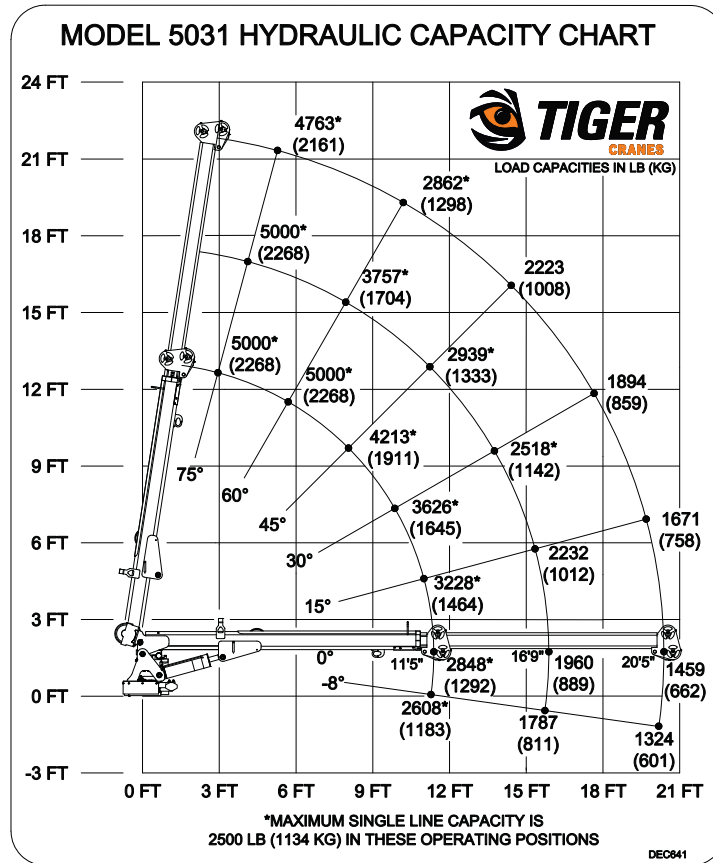

Bolt Hole Pattern

